

19



**Octrooi Centrum
Nederland**

11

2034260

12 B1 OCTROOI

21 Aanvraagnummer: **2034260**

51 Int. Cl.:
G06F 3/0354 (2023.01) G06V 30/142 (2023.01)

22 Aanvraag ingediend: **3 maart 2023**

62

30 Voorrang:
29 september 2022 NL 2033190

73 Octrooihouder(s):
Nuwa Pen B.V. te Groningen

41 Aanvraag ingeschreven:
8 april 2024

72 Uitvinder(s):
**Marc Tuinier te Groningen
Shubham Koyal te Groningen
Cas Kempers te Groningen
Franciszek Pawel Szewczyk te Groningen
Breno Cunha Queiroz te Groningen
Riordan Benjamin Boyd Maduro te Groningen
Vishal Raveendranathan te Groningen**

43 Aanvraag gepubliceerd:
-

47 Octrooi verleend:
8 april 2024

45 Octrooischrift uitgegeven:
15 april 2024

74 Gemachtigde:
ir. H.A. Witmans c.s. te Den Haag

54 Handwriting detecting pen

57 A handwriting detecting pen, including a writing device (1) for performing a writing operation on a writing surface (S) of a substrate (P), wherein the writing device (1) has a camera system (5) for recording at least part of the writing surface (S) during operation, characterized in that a field of view of the camera system is at least 90 degrees, preferably at least 110 degrees, for example about 125 degrees. The writing device can record markings (e.g. writing) made by the device on a substrate within a relatively large range of orientations of the writing device with respect to the writing surface. The optically recorded markings can e.g. be processed by the writing device (in particular by a respective image processor thereof) to generate output data representing, containing or being associated with the recorded markings.

P133425NL00

Title: Handwriting detecting pen

The invention relates to a handwriting detecting pen.

5 Various examples of handwriting or symbols/markings detecting pens are known from the prior art. For example, EP0856810 discloses a handwriting detecting and storing apparatus that comprises a lens having a cone shape at a front-most position of a lens system which introduces handwriting image to image pick up means such as a charge-coupled device
10 or the like. The known pen includes a pen shaft provided at a center of the lens having a cone shape, and wherein an optical axis of the lens system, an optical axis of the lens having a cone shape and a central axis of the pen shaft are coincident with one another, so that a writing operation is performed using a writing device, handwriting image is picked-up and
15 picked up handwriting information is stored therein. During operation, an image within the picked up field of view is stored as an image that includes deformed writing within a region neighboring a point just below the leading edge of the pen stylus when no correction processing is applied. To correct for the deformation, the deformed region of the image is subjected to image
20 processing and is corrected by a correction means. By applying the correction processing, accurate handwriting with no deformations included in a region neighboring a shadow region is reproduced.

US5294792 discloses a self-contained pen computer that is capable of acquiring data representative of written strokes of the stylus of the pen
25 and then recognizing the symbols associated with these pen strokes, or compacting these strokes. These recognized symbols or compacted strokes are stored in a memory contained in the pen and are transmitted via a transmitter contained in the pen to a host computer. The pen utilizes a stylus movement detector and a stylus up/down detector, digitized signals of
30 which are fed to a hand print recognition chip. According to an embodiment,

capacitively coupled device (CCD) scanning elements are employed to detect the symbols on the paper written by the stylus of the pen. For this embodiment, a ring of CCDs are placed near the stylus end of the pen. A suitable lens system (that is blended into the exterior of the pen) provides the ring of CCDs with a very narrow field of view immediately adjacent the pen stylus. In this manner, as the stylus makes a mark on a writing surface that mark is detected by one or more CCDs and converted by a digitizer into a peak voltage localized to a particular position relative to an arbitrarily assigned "up" (or zero degrees) position. An infrared (IR) light emitting diode (LED) mounted in or on the exterior of the pen near the writing end may provide illumination for the CCDs if the incident light level is too low for the CCDs to operate satisfactorily. As the CCD ring's pulsed output is provided to the digitizer, it represents a line detection and relative position, as well as a relative length based on the number of occurrences (which depends upon the CCD clocking rate) at that same relative position. In this manner, lines, their crossings and other suitable types of input data may be supplied to the recognition chip for analysis and recognition, or compaction. The CCD embodiment of the pen computer of the present invention may be particularly useful for recording information and/or authorizations for particular types of forms. If the data is stored along with a time stamp, i.e. a time and date of the storing, it is possible to correlate receipt of information and/or authorizations. For example, a specific form could have a barcode at its top that could be scanned by the CCDs and stored to identify what information was written on that form and when it was authorized by a signature. This would provide a hard copy form, as well as an electronic audit trail with the time stamped information and/or authorization for that form.

The publication 'Smart pen and related method for detecting ink applied by a smart pen onto a writing surface', Technical Disclosure Commons, Defensive Publications Series October 06, 2017 discloses a smart

pen, equipped to differentiate content created on the writing surface using the pen from other content contained on the writing surface. The smart pen is provided with a specialized type of ink that is configured to reflect light when illuminated with a given light source, thereby allowing the ink to be easily identified or detected within images captured via a camera of the smart pen.

US2016/0018910 discloses pen shaped hand-held instrument for processing a substrate, comprising: at least one pen tip; a shaft; at least one optical sensor; and at least three acceleration sensors, wherein the pen tip is in contact with the substrate in an operating position of the hand held hand held instrument, wherein the at least one optical sensor is arranged proximal to the pen tip at an end of the hand held instrument that is oriented towards the substrate. The optical sensor has an image angle of at least 90°, wherein at least an identification portion which includes a portion of the substrate and at least a lateral edge of the substrate and at least a portion of a surrounding area of the substrate which is directly adjacent to all edges of the substrate is detectable from an identification position in which the pen tip has a distance from the substrate, wherein the at least three acceleration sensors are respectively arranged perpendicular to each other and continuously detect an acceleration of at least a portion of the hand held instrument in a three dimensional space. The pen is used to detect at least a coarse pattern from an identification position in which the pen tip has a distance from the substrate. In this way, a unique association of the hand held instrument with a substrate and/or a detection of a change of the substrate can be facilitated in that a sufficiently large portion of the substrate is optically detected, wherein a “coarse pattern recognition” is performed by the at least one optical sensor. This means that it is not required that the portion of the substrate is detected with full resolution; the detected image may rather be slightly unfocused. Thus, it is sufficient when a coarse pattern is detected.

Disadvantages of such known systems include relative user-unfriendliness, wherein the systems can require special paper (having specific markings) and/or special ink for operation. In addition, known systems can require the user to hold the pen at a specific orientation with respect to the paper in order to function properly.

The present invention aims to provide an improved handwriting detecting pen, in particular a pen that is user friendly and reliable. To that aim, there is provided a pen as defined in the features of claim 1.

According to an aspect of the invention there is provided a handwriting detecting pen, including a writing device for performing a writing operation on a writing surface of a substrate, wherein the writing device has a camera system for recording at least part of the writing surface during operation, wherein a field of view of the camera system is at least 90 degrees, preferably at least 110 degrees, for example about 125 degrees.

It has been found that in this way, the writing device can record markings (e.g. writing) made by the device on a substrate within a relatively large range of orientations of the writing device with respect to the writing surface. The optically recorded markings can e.g. be processed by the writing device (in particular by a respective image processor thereof) to generate output data representing, containing or being associated with the recorded markings.

Herein, the field of view (FOV) of the camera system can be defined as the field of view provided by the camera system to the pen. It is preferred that a central axis of the FOV coincides with a central axis (center line) of the pen, extending e.g. centrally through an ink dispensing tip of the pen. The pen's FOV (as provided by the camera system) is preferably a substantially conical field of view (i.e. the FOV is bounded by a virtual cone), a top angle of the cone being at least 90 degrees.

The pen as such can be configured in various ways, and it will be appreciated that the writing device can have a distal writing tip and a

respective ink reservoir for feeding ink to the writing tip. The pen can include e.g. an elongated pen housing for containing the ink reservoir (which may be a rechargeable and/or replaceable ink reservoir), the housing being handheld by a writer/user/marker during pen operation. The camera system
5 can e.g. be located at or near a distal end of the pen housing, i.e. near a respective writing tip. Ink that is used by the pen is preferably normal ink, i.e. ink that is directly readably by a user under normal lighting conditions.

According to a highly preferred embodiment, the camera system has three camera units, having mutually different viewing angles,
10 preferably symmetrically arranged with respect to a centerline of a housing of the writing device, in particular for recording respective sets of images that encompass the entire field of view of the camera system.

Thus, a large field of view can be achieved (wherein field of views of the three camera units combine to provide the overall FOV of the camera
15 system) and reliable recording of pen written markings. It is preferred that the three camera units are arranged such that their individual FOVs partly overlap. It has been found that in case only three camera units as used, optimum results in a compact pen configuration can be obtained. Each of the cameras can e.g. be a CCD (charged-coupled device) camera. An optical axis
20 of each of the three cameras preferably includes an angle in the range of 5-45 degrees (for example an angle in the range of 20-30 degrees) with respect to a center line of the pen. Preferably, the optical axes of the three camera units mutually diverge with respect to each other. Herein, an optical axis of a camera unit is defined as the optical axis of a respective field of view
25 provided by the respective unit (e.g. the optical axis extends through a respective outer light transmitting aperture of the pen).

According to a preferred embodiment, the writing device includes a processor configured to process images received from the camera system to determine handwriting data concerning handwriting on a recorded writing
30 surface section, the processor preferably being configured to evaluate and/or

store detected handwriting data. Good results are achieved when the processor is configured to convert bitmap images into vector space data, preferably using a suitable algorithm (for example an edge detection algorithm), and process the resulting vector space data to determine the
5 handwriting data. In this way, efficient and reliable image processing can be achieved by the pen itself. Regarding the term 'bitmap', it is noted that a bitmap image is an image made of pixels (<https://en.wikipedia.org/wiki/Bitmap>).

Besides, it has been found that efficient data processing can be
10 achieved in case the processor is configured to determine an orientation of the writing device with respect to the writing surface, wherein the processor is preferably configured to utilize a determined orientation of the writing device with respect to the writing surface in transforming a coordinate system of determined handwriting data to a coordinate system of the
15 writing surface.

According to a preferred embodiment, the pen includes at least one inertial measuring unit (IMU), for example including a gyroscope and/or accelerometer, wherein the processor is configured to determine the orientation of the writing device with respect to the writing surface using
20 sensor results of the at least one inertial measuring unit. In that case, it has been found that improved, accurate pen orientation can be determine in case the pen including a first inertial measuring unit at or near a proximal end of the writing device and a second inertial measuring unit at or near a distal end of the writing device (wherein measurements of both IMUs can be
25 used by the processor for determining the orientation of the writing device with respect to the substrate/writing surface).

Moreover, according to a preferred embodiment the processor is configured to process the images received from the camera system to detect at least one edge of the substrate's writing surface (i.e. the edge being an
30 edge of the substrate as such). In addition or alternatively, one or more

other algorithms can be applied by the processor to process the images, for example a skeletonization algorithm (see e.g.

https://en.wikipedia.org/wiki/Topological_skeleton, providing different algorithms for computing skeletons for shapes in digital images).

5 By carrying out edge detection, the processor can better define a pen orientation with respect to the writing surface (i.e. substrate). In that case, the processor can be configured to convert bitmap images into a vector space data, using an edge detection algorithm, and process the resulting vector space data to determine edge data concerning the at least one edge of the substrate's writing surface. As an example, 2D coordinates X_{eb} , Y_{eb} of a detected edge of the substrate (e.g. $X_{eb}=100$, $Y_{eb}=200$) can be associated or linked to a 2D central reference coordinate X_{ev} , Y_{ev} (e.g. $X_{ev}=0$, $Y_{ev}=0$) of the vector space.

15 Preferably, the pen includes at least one light source, for example a light emitting diode (LED), for illuminating at least part of the writing surface with light, for example infrared light and/or visible light. In this way, improved pen operation can be achieved under low-light conditions, wherein the light source can provide (additional) surface illumination for detecting any pen written markings.

20 The writing device preferably includes a (distal) cap having at least one light transmission section, for example an opening or transparent wall section, for transmitting incoming light to the camera system. In case of three camera units, the cap can e.g. include three respective light transmission sections. Moreover, in case of an integrated light source, it is preferred that the cap includes additional one or more light emitting sections for emitting illumination light of the light source(s). Moreover, then, it is preferred that the pen includes a light guide structure for guiding light from the or each light source to a respective light emitting section of the cap. In this way a compact configuration can be achieved that provides optimized writing surface illumination. Besides, light receiving sections of

25

30

the cap can be separate from light emission sections, and the optional lightguide structure can be configured for guiding source light along one or more internal paths that are separate from optical paths concerning incoming light that is to be detected by the camera system, thereby avoiding
5 direct interference of source light with camera system operation. Also, it is preferred that the pen includes a light diffuser (which can e.g. be part of or integrated with said cap) for diffusing light emanating from the light source. As is mentioned before, the light can be e.g. infrared light, and/or visible light (e.g. light having a wavelength in the 400-700 nm range).

10 Further extra advantageous embodiments of the invention are provided in the dependent claims.

A non-limiting example of the invention is depicted in the drawings. Therein shows:

Figure 1 an isometric view of an embodiment of the invention;

15 Figure 2 a top view of the embodiment;

Figure 3 a side view of the embodiment;

Figure 4 a detail A of Figure 3;

Figure 5 a front view of the embodiment;

Figure 6 an exploded view of part of the embodiment;

20 Figures 7A and 7B an isometric front view and isometric back view, respectively, of a tip section of the embodiment;

Figures 8A and 8B an isometric front view and isometric back view, respectively, of a light guide section of the embodiment;

25 Figures 9A and 9B an isometric front view and isometric back view, respectively, of an interior cover of the embodiment;

Figures 10A and 1B an isometric front view and isometric back, respectively, view of an interior positioning section of the embodiment;

Figures 11A and 11B an isometric front view and isometric back view, respectively, of a camera section of the embodiment;

Figures 12A and 12B an isometric front view and isometric back view, respectively, of a housing section of the embodiment;

Figure 13 a side view of the embodiment during operation, at a first pen orientation;

5 Figure 14 a side view of the embodiment during operation, at a second pen orientation; and

Figure 15 an isometric back view of the embodiment, indicating a field of view of the camera system.

10 Similar or corresponding features are denoted by similar or corresponding reference signs in this application.

The drawings show a non-limiting example of a handwriting detecting pen. The pen includes a writing device 1 for performing a writing operation on a writing surface S of a substrate P (see Figures 13, 14). The writing device 1 has a distal writing tip 1a and a respective ink reservoir 1b (schematically indicated in Fig. 2), containing ink, for feeding ink to the writing tip 1a (e.g. via an in feeding channel 1c there-between). The pen 1 can include an elongated housing, containing the ink reservoir 1b. Further, the writing device 1 has a camera system 5 for recording at least part of the writing surface S during operation. For example, a housing 2 of the pen 1 can be provided with a distal head section 2a containing the camera system 5 and other components (e.g. an optional light source). Figures 6-12 shows various components of the camera system 5 in more detail.

The total field of view of the camera system is at least 90 degrees, preferably at least 110 degrees for example about 125 degrees. The respective FOV angle is indicated by angle α in Figures 13, 14, as well by area's FOV(a), FOV(b) and FOV(c) in Figure 15 (which concern field of views associated with the individual camera units 5a, 5b, 5c of the exemplary camera system 5). The overall FOV of the camera system 5 is preferably symmetrical with respect to a center line X of the pen (the center line extending centrally through the distal writing tip 1a).

In particular, the camera system 5 can be arranged for recording images encompassing the pen's total FOV. Due to the large FOV, relatively large sections of the writing surface can be detected, independently of pen orientation (e.g. a writing angle with respect to the ink receiving surface S as well as a pen's rotational position with respect to the pen's central axis X) with respect to the surface S. Moreover, as will be explained below, the large FOV makes it possible to detect an edge or corner of the respective substrate (e.g. paper) P providing the writing surface, for example in case the substrate has a regular A4 size (i.e. 210 x 297 mm).

Good results are achieved in case the camera system has (only) three camera units 5a, 5b, 5c, having mutually different viewing angles. Each of the camera units 5a, 5b, 5c can include a sensor, e.g. a CCD sensor, for digitally recording respective images. It is preferred that each of the camera units 5a, 5b, 5c is configured to generate bitmap images. Also, e.g., each camera unit 5a, 5b, 5c can include projection optics, e.g. one or more optical elements or lenses, for projecting incoming light onto the sensor. Figure 11a shows example of camera lenses 15a, 15b, 15c of the respective camera units. An optical axis OA of each of the three camera units 5a, 5b, 5c can enclose an angle β (preferable the same angle β), with a center line X of the pen (the angle β being measured in a plane that includes the respective optical axis OA as well as the center line X), for example an angle in the range of 5-45 degrees (for example a range of 20-30 degrees). Two of the three optical axes of respective camera units are indicated by dashed lines OA(a) and OA(b) in Figure 1.

Also, preferably, the optical axes of the three camera units mutually diverge with respect to each other. The three camera units 5a, 5b, 5c (and their corresponding optical axes) are preferably symmetrically arranged with respect to the center line X of the housing 2 of the writing device 1, in particular for recording respective sets of images that encompass the entire field of view FOV of the camera system 5. To that aim,

e.g., the three camera units 5a, 5b, 5c can be equidistantly symmetrically arranged around the pen's center line X (see the drawings), for example having respective camera lenses 15a, 15b, 15c (if any) being tilted with respect to the pen's center line X to provide respective diverging field of views (i.e. mutually diverging optical axes OA).

The writing device 1 can e.g. include a support structure 5d for supporting and positioning the camera units 5a in a head section 1c of the pen. The camera support structure 5d can include e.g. a sleeve having three L-shaped arms 5e for holding the camera units 5a at respective positions. The sleeve 5d and arms 5e can e.g. surround a space that can receive other pen components after assembly, e.g. a processor 10 and/or power source 11 (see Fig. 6) and/or IMU, as well part of an ink reservoir 1b and/or ink feeding channel 1c.

Further, the writing device 1 can include a support element 6, configured for supporting (and e.g. surrounding) the camera units 5a after assembly. The support element 6 can e.g. be located near the camera system, within a head section 2a of the pen. The support element 6 can include e.g. apertures 6c (e.g. U-shaped openings/apertures) for receiving the camera units 5a of the camera system, so that a compact assembly can be achieved. Also, the support element 6 can include a central opening 6d for receiving an ink feeding channel 1c of the pen, and e.g. for receiving one or more optional light guides such as optical fibers (not shown) for guiding light (e.g. infrared light and/or visible light) from one or more light sources towards a cap 3.

The writing device 1 includes a processor 10 configured to process images received from the camera system 5 to determine handwriting data concerning handwriting on a recorded writing surface section. The processor 10 is schematically indicated in Figure 6. The processor 10 can be communicatively connected to the camera units 5a, 5b, 5c for receiving digitally registered images therefrom. Optimally, the processor 10 and

camera system 5 can be integrated with each other and/or e.g. be provided on a single PCB (printed circuit board). The skilled person will appreciate that the processor 10 can be provided by suitable hardware, executing processor software for carrying out processor functionality. The processor
5 can e.g. be or include a digital microcontroller, a digital signal processor, and/or the-like. It is preferred that the processor has a digital memory for storing the images and e.g. for storing processed images and e.g. other processing results. Also, according to an embodiment, the processor can include or be provided with communication means, for wirelessly
10 communicating with a remote device (e.g. a smartphone, tablet or computer), the communication means e.g. being configured to use a standard communication protocol (e.g. WIFI, Bluetooth™ or the-like).

Further, the writing device 1 can include a power source 11, e.g. a (rechargeable) battery, for electrically powering other components, such as
15 the camera system and the processor 10. Besides, the writing device 1 can include a charging terminal 14 for charging the power source 11 using external power, in case a rechargeable battery is implemented.

Also, the writing device 1 can include a user interface 12 (see Fig. 1), for example display and/or light signaling units (e.g. light emitting
20 diodes) and/or or a haptic feedback unit (e.g. one or more linear resonant actuators) for informing an operator of writing device operation (e.g. battery status). For example, the writing device 1 can include a user operable element, e.g. a switch or button, for controlling the device, such as for activating and/or deactivating the camera system and/or processor.
25 According to an embodiment, the pen tip 1a can be configured to provide the user operable element, wherein the tip 1a e.g. includes a (pressure) sensor that is configured to detect placement or pressure on the writing surface, wherein he tip sensor can be communicatively connected to the processor 10 for providing a sensor signal thereto (in which case the processor 10 can e.g.
30 initiate image processing in case the tip sensor signal indicates pen

placement, and wherein the processor 10 can e.g. halt image processing in case the tip sensor signal indicates that the tip has not contacted a writing surface anymore for a certain amount of time).

The processor 10 is preferably configured to evaluate and/or store
5 detected handwriting data. As will be explained below in more detail, the processor 10 is preferably configured to convert bitmap images (received from the camera units 5a, 5b, 5c during operation) into a vector space data, preferably using an edge detection algorithm, and process the resulting vector space data to determine the handwriting data. In this way, efficient
10 and reliable image processing can be achieved by the pen.

Also, it is preferred that the processor 10 is configured to determine an orientation of the writing device 1 with respect to the writing surface (during use of the pen). The processor 10 is preferably configured to utilize a resulting -determined- orientation of the writing device 1 with respect to the
15 writing surface S in transforming a coordinate system of determined handwriting data to a coordinate system of the writing surface S. Thus, enhanced processing of images received from the camera system 5 can be achieved.

In order to determine writing device orientation, the pen can
20 include at least one inertial measuring unit IMU 13, for example including a gyroscope and/or accelerometer, wherein the processor 10 is configured to determine the orientation of the writing device with respect to the writing surface using sensor results of the at least one inertial measuring unit 13. Optimum results can be achieved in case the pen includes a first inertial
25 measuring unit 13a at or near a proximal end of the writing device 1 and a second inertial measuring unit 13b at or near a distal end of the writing device 1. Optionally, the second IMU 13b can be located at or near the camera system 5. The two IMUs 13a, 13b can e.g. be spaced-apart over a distance of at least 5 cm.

According to a preferred embodiment, the processor 10 is (also) configured to process the images received from the camera system 5 to detect at least one edge of the substrate's writing surface S. In that case, the processor 10 can be configured to convert the afore-mentioned bitmap images into a vector space data, preferably using an edge detection algorithm, and process the resulting vector space data to determine edge data concerning the at least one edge of the substrate's writing surface S. For example, the processor 10 can be configured to determine an orientation and/or a position of the writing device 1 with respect to the writing surface using the determined edge data.

The device 1 preferably includes a distal cap 3, e.g. having conical external cap surface. The cap 3 is shown in more detail in Figures 4, 5, 7A, 7B. The cap 3 has a central aperture/orifice 3a for receiving the writing tip 1a.

Further, the cap 3 can include three light transmission sections 3b, for example optically transparent wall sections or openings 3b, for transmitting incoming light to the three camera units of the camera system 5 (each transmission section 3b being associated with one of the camera units 5a, 5b, 5c). In case the light transmission sections are wall sections, each of those light transmitting wall sections 3b is preferably made of a material that does not diffuse incoming light, e.g. transparent glass or transparent plastic. Each of the light transmission sections 3b can e.g. extend normally with respect to a respective camera unit's optical axis OA (and e.g. be tilted with respect to a plane Y that is normal to the pen's center line X).

Also, the cap 3 can include radially inwardly extending wall sections 3c (i.e. inwardly with respect to a cap's conical outer surface) providing three light entry ports/apertures leading towards the three transmission sections 3b. The radially inwardly extending wall sections 3c of the cap 3 can e.g. extend substantially in parallel with each other and

with the center line X of the pen, and can be e.g. be slightly curved or straight wall sections, wherein proximal edges 3d of these wall sections 3c can be located at radially inward edges of the respective light transmission sections 3b. Similarly, distal edges 3e of the radially inward wall sections 3c can be located at or near the central distal aperture 3a of the cap 3. Also, the three light transmission sections 3b of the cap can be symmetrically arranged with respect to the center line X of the writing device 1, in particular equidistantly symmetrically arranged around the pen's center line X.

As follows from Fig. 5, each of the three light transmission sections 3b can be substantially square or rectangular, or trapezium shaped e.g. having rounded corners, when viewed in front view, but that is not required. In particular (see Fig. 5), a radial width R of each of these light transmission sections 3b can be about the same as a circumferential width W of that wall section (the radial width e.g. being in the range the circumferential width plus and minus 20% of that circumferential width), providing a relatively large light entry surface for the respective camera unit.

The pen preferably includes at least one light source (e.g. an infrared light source, and/or a light source for emitting visible light such as light having a wavelength in the range of 400-700 nm), for example including one or more light emitting diodes, for illuminating at least part of the writing surface S with light. For example, each light source can be configured to be automatically activated during operation, by the processor 10 and/or camera system 5, in case of low-light conditions. The light source can e.g. be powered by a pen's power source 11.

A non-limiting example of the light source is depicted in Figures 10A, 10B, showing that the support element 6 can have a light source support section 6a having three spaced-apart light emitting devices 6b.

The three light emitting devices 6b can be symmetrically arranged with respect to the center line X of the writing device 1, in particular equidistantly symmetrically arranged around the pen's center line X. The light source support section 6a can include e.g. apertures 6c (e.g. U-shaped openings/apertures) for receiving the camera units 5a of the camera system, so that a compact assembly can be achieved. Also, the support section 6a can include a central opening 6d for receiving an ink feeding channel 1c of the pen.

Alternatively, for example, one or more light sources can be separate from the support element 6, for example located proximally with respect to the support element 6, in which case emitted light can be transmitted from the or each light source to the cap 3 via one or more optical fibers (not shown) extending through the central aperture 6d of the support element 6.

Also, the pen preferably includes an light guide structure 9 for guiding light from the (or each) light source 6 to light emitting sections 3f (e.g. openings) of a distal cap 3 of the pen.

The present cap 3 has three separate light emitting section 3f, for emitting illumination light of the light source 6 (however, more or less than three such light emitting sections can be applied). Preferably, separate light emitting sections 3f and the light receiving sections 3b of the cap are arranged such that emitted light (emitted by the light guide structure 9 via the light emitting sections 3f) can not directly reach the light receiving sections 3b. For example, intermediate light blocking sections 3g of the cap 3 can prevent light transmission from the light emitting sections 3f to the light receiving sections 3b.

Preferably, the device includes an light diffuser for diffusing light emanating from the light source. For example, the light guide structure 9 can be configured to diffuse the light that it emits via the emitting sections

3f of the cap (for example, the light guide structure 9 can include optically translucent material, for diffusing the light that is to be emitted).

Each of the cap's light emitting sections 3f can e.g. extend in/along a conical plane defining an outer surface of the cap. As follows from
5 Figure 4, the light emitting sections 3f can be located distally with respect to the light receiving sections 3b of the cap 3. Also, the light emitting sections 3f of the cap can be symmetrically arranged with respect to the center line X of the writing device 1, in particular equidistantly symmetrically arranged around the pen's center line X. As follows from Fig. 5, each of the three light
10 emitting sections 3f can be substantially droplet shaped when viewed in front view but that is not required. Also, a circumferential width K of each of the three light emitting sections 3f can be significantly smaller than the circumferential width W of the light transmission sections 3b, e.g. at least 2x smaller and in particular at least 3x smaller. Also, distal edges of the
15 light emitting wall sections 3f can be located at or near the central distal aperture 3a of the cap 3.

The pen preferably includes an light guide structure 9 for guiding light from the light source 6 to each emitting section 3f of the cap 3. The light guide structure 9 can be arranged within the pen head section and/or
20 cap, and can be positioned between the light source 6 and the light emitting sections of the cap. The light guide structure 9 can include a central aperture 9a for receiving the pen's ink feeding channel 1c. The light guide structure 9 can be configured to transmit light, received from the light
25 source 6, towards (and e.g. through) the cap sections 3f using total internal reflection. According to one embodiment, the light guide structure 9 can be entirely made of transparent material. Alternatively, at least part of the light guide structure 9 can be made of translucent material, for diffusing the light.

In the present exemplary embodiment the light guide structure 9
30 includes three spaced-apart light guiding teeth 9b, that can be joined or

mounted e.g. on a central ring-shaped support part 9e. Each of the teeth 9b can include a proximal light entry surface 9c that is positioned opposite a respective light emitting section 6b of an afore-mentioned light source 6 (or optical fiber output end) after assembly. Also, each of the teeth 9b can
 5 include a distal light exit section 9d that is positioned opposite or in (e.g. protrudes through) a respective light emitting section 3f of the cap 3. For example, the three proximal light entry surfaces 9c can extend substantially along the same virtual plane, substantially perpendicular (radially) with respect to the pen's center line X. The distal light exit sections 9d can e.g.
 10 extend substantially along a virtual conical plane that extends along an inner surface of the cap 3. It is preferred that the distal light exit sections 9d snugly fit in the respective light emitting sections 3f of the cap after assembly. Also, preferably, the three distal light exit sections 9d of the light guide structure 9 have substantially the same shape as the respective light
 15 emitting sections 3f of the cap. According to an embodiment, radially inner edges of the light guide structure 9 (e.g. of the three teeth 9b) can extend in parallel. Also, each of the teeth 9b can include a sharp distal tip that can be located near the cap's central aperture 3a.

Optionally, the head and/or cap section of the pen can include
 20 additional components, for example an internal optically transparent cover member or circular platelet or lens 8 that can e.g. be provided on top of the camera system 5 and/or light source 6 for protecting and/or positioning of such elements. The internal cover member (e.g. lens) 8 can e.g. have a central opening 8a, e.g. for receiving a said central support part 9e of an
 25 optional light guide structure 9 and for allowing passage of said ink feeding channel 1c, and e.g. for passage of one or more optional light guides (e.g. optical fibers) for transmission of light to the cap.

During operation, a user can write markings, e.g. writing or a drawing, onto a writing surface S of a substrate (e.g. paper) P. The camera
 30 units 5a, 5b, 5c of the pen record images which are received and processed

by the processor 10. Due to the large FOV of the pen, and the respective configuration of the camera system, optimum recording of the writing surface can be achieved, wherein the pen can be dimensioned relatively compact providing a user-friendly writing experience. Also, the pen can be orientated at a large number of angles with respect to the writing surface, within a range of 0-360 degrees of a rotational position around the pen's center axis X.

During operation, the integrated processor 10 can process the bitmap images received from the camera system 5 to determine handwriting data concerning handwriting on a recorded writing surface section. The processor 10 can evaluate and/or store detected handwriting data, and can convert bitmap images into vector space data, using an edge detection algorithm, and process the resulting vector space data to determine the handwriting data. A non-limiting example of the processing is explained below in more detail. Also, the processor 10 can determine the instantaneous orientation of the writing device 1 with respect to the writing surface S, wherein the processor can utilize the determined orientation of the writing device 1 with respect to the surface S in transforming the coordinate system of determined handwriting data to the coordinate system of the writing surface S. The actual orientation of the writing device 1 can e.g. be determined using data received from the two IMUs and/or by detected edge data concerning the writing surface. Preferably, both the determined edge data and IMU data are used in the orientation determination.

Operation of the pen can in particular include conversion of recorded bitmap images to vector space, however, it will be clear that other types of image processing and computer vision can be implemented. An example of a conversion (which can be carried out by the pen's processor 10) is explained in the following.

A first step in converting each recorded image into a vector space, by the processor 10 can include separating handwriting from the substrate and the substrate from the environment (e.g. the substrate, paper, an environment of the substrate, a table, etc.). A result of this step can be a
5 bitmap image wherein each pixel can be marked as either background or as handwriting or as substrate edge. Therein, e.g. white parts of the image (handwriting) can be 1 pixel wide. For example, in one image processing step, the processor 10 can mark pixels as being either background (e.g. substrate) pixels, substrate edge pixels (e.g. for position estimation) or
10 handwriting pixels. Further, to that aim, the image processor 10 can be configured to determine local gradients and local exposure levels in the bitmap image.

The respective image processing, by the processor 10, can include the following steps 1-5 (wherein not all steps are required to provide good
15 end results):

Step 1. A smoothening step, wherein the image is smoothed in order to reduce noise;

Step 2. An exposure adjustment step wherein the image's local and global exposure levels are adjusted in such a way that the contrast between
20 the handwriting, the substrate and the environment is as high as possible;

Step 3. Carrying out an edge detection algorithm (e.g. a canny edge detection algorithm):

3a. Image's local gradients (directional change in pixel intensity) are calculated;

25 3b. Pixels with gradient values below a low threshold are rejected and marked as background;

3c. Pixels with gradient values above a high threshold are marked as strong edges;

3d. Pixels with gradient values between low and high threshold are marked as strong edges only if they are neighbouring with a strong edge. Otherwise, they are marked as background; and

5 3e. Outputting the result of the previous steps 3a-3c, the result being a bitmap where each pixel is either marked as background or as a strong edge.

Step 4. A convolution step, wherein convolution is performed by the processor on the image in such a way that pixels are marked as either strokes or background or substrate edge, while ensuring that:

10 4a. Stroke marked chains of pixels are 1 pixel wide; and

4b. Stroke marked edges lie exactly in between two pixels marked previously as strong edges.

Step 5. Outputting a final result, which is a bitmap, where each pixel is either assigned as background or handwriting or substrate edge. Therein, the handwriting pixels preferably form lines of 1 pixel width.

Next, Vector Space Conversion (VSC) can be initiated by the processor 10, using the results from above steps 1-5. Vector space conversion as such is commonly known (see e.g. <https://github.com/LingDong-/skeleton-tracing>).

20 For example, given the bitmap with pixels marked as handwriting (i.e. the output of Step 5), the processor 10 can operate to identify polylines, that is consecutive neighboring handwriting pixels. Herein, a polyline can be defined as consisting of points whose coordinates are defined by its pixel location. Furthermore, each polyline ends once there are no more neighboring handwriting pixels or a specific point has more than 1

25 Then, the VSC (carried out by the processor 10) can be as follows (steps A1-A7):

A1. Given as input is the bitmap with pixels marked as either background or handwriting or substrate edge;

A2. If the width and height of the image are both smaller than a small, pre-determined size, go to step A7.

A3. Raster scan the image to find a row or column of pixels with qualities that best match the following:

- 5 a. Has the least amount of pixels on itself;
- b. The 2 submatrices divided by this row or column do not have pixels on their four corners; and
- c. When two or more candidates are found, pick the one that is closer to the center of the image.

10 A4. Split the image by this column or row into 2 submatrices (either left and right, or top and bottom depending on whether row or column is selected in the previous step A4).

A5. Check if either of the 2 submatrices is empty (i.e. all 0-pixels). For each non-empty submatrix, recursively process it by going to step A2.

15 A6. Merge the result from the 2 submatrices, and return the combined set of polylines.

For each polyline from one submatrix whose either endpoint coincides with the splitting row or column, the processor 10 can be configured to find another polyline in the other submatrix whose endpoint meets it. If the matrix was split horizontally, then the x-coordinate of the endpoints can differ by exactly 1, and y-coordinate can differ between 0 to about 4 (depending on the steepness of the stroke portrayed), The reverse goes for vertical splitting.

20

A7. Recursive bottom: Walk around the 4 edges of this small matrix in either clockwise or ant-clockwise order inspecting the border pixels:

25

- a. Initially set a flag to false, and whenever a pixel is encountered whilst the flag is false, set the flag to true, and push the coordinate of the 1-pixel to a stack;

b. Whenever a background pixel_or substrate edge pixel is encountered whilst the flag is true, pop the last coordinate from the stack, and push the midpoint between it and the current coordinate;

Then set the flag to false;

5 c. After all border pixels are visited, the stack now holds coordinates for all the "outgoing" (or "incoming") pixels from this small image section. By connecting these coordinates with the center coordinate of the image section, an estimated vectorized representation of the skeleton in this area is formed by these line segments.

10 Preferably further improve the estimate using the following heuristics:

d. If there are exactly 2 outgoing pixels, it is likely that the area holds a straight line. Then, return a single segment connecting these 2 pixels;

15 e. If there are 3 or more outgoing pixels, it is likely that the area holds an intersection, or "crossroad". Then, carry out a convolution on the matrix to find the 3x3 submatrix that contains the most pixels. Set the center of all the segments to the center of the 3x3 submatrix and return; and

20 f. If there is only 1 outgoing pixel, find and return the endpoint of the polyline.

Stroke Generation

After the generating of the set of Polylines (a set of point lists), the processor 10 can be configured to group them together into Strokes (letters etc.) and transform them onto the substrate's coordinate system. This can
25 e.g. be achieved by the processor 10 as via the following steps B1-B2:

B1. Performing a Depth-first search on found polylines in order to mark interconnected polylines and create a set of individual Strokes.

30 B2. Given current orientation (x, y, z) of the camera relative to the substrate (e.g. paper), map pixel coordinates to local substrate (plane) coordinates.

Substrate Edge Detection.

The processor 10 can carry out the following Line Detection steps:

D1-D3:

- D1. Carry out Line Detection (e.g. RANSAC line detection, i.e. Random Sample and Consensus line detection):
- a. randomly select two points previously marked as substrate edges;
 - b. create a line between these two points;
 - c. count how many substrate edges lie on that line;
 - 10 d. If the number of these points is greater than certain threshold, add that line to a set of suspect lines; and
 - e. Go back to a. for a certain number of iterations.
- D2. Given the set of suspect lines, select the lines that are most likely to be correct substrate edges based on:
- 15 a. length - the longer the detected line (the more potential edge points lie on it) the better;
 - b. angle – substrate edges are likely to be either vertical or horizontal (works only if are aware of the substrate orientation on the a support, e.g. table); and
 - 20 c. angle between the pair of edges - edges of the substrate form either a right angle (vertical + horizontal) or they are parallel and at a certain distance from each other (top + bottom).

According to a preferred embodiment, the line detection steps, carried out by the image processor 10, can optionally make use of a 3D orientation (x,y,z) of the device and 2D-position (x, z) of the device determined from data of the IMUs 13a, 13b. For example, the above line selecting steps D2(a-c) can include a step d:

- d. expectations from the IMU: estimation current orientation and position of the writing device (using IMU data), and predicting edge

placement within the bitmap based on the estimation of the current orientation and position of the writing device.

D3. Decide on detected edges of the substrate, and calculate the tip's global position of the substrate and use this information for further
5 processing.

It is self-evident that the invention is not limited to the above-described exemplary embodiments. Various modifications are possible within the framework of the invention as set forth in the appended claims.

For example, it will be appreciated that the processor 10 can be
10 located in various positions within a housing of the pen 1, e.g. near the camera system or differently. The same holds for other components, such as an integrated battery (if any).

Also, for example, an afore-mentioned light emitting section and light guide structure can be configured in various ways, e.g. for emitting
15 infrared light and/or visible light, as will be appreciated by the skilled person. As an example, one or more optical fibers can be provided to provide the at least one light emitting section (i.e. infrared light emitting section and/or visible light emitting section), and for providing the respective (infrared and/or visible light) light guide structure. Furthermore, in an
20 embodiment, use is only made of infrared light (the pen having an infrared light source), or of visible light (the pen having a light source emitting visible light). In yet another embodiment, both infrared light and visible light can be emitted (and guided) by the pen, in case the light source is configured to generated such light e.g. in case of a light source having at
25 least one LED emitting visible light and at least one LED emitting infrared light).

Conclusies

1. Handschriftdetectiepen, omvattende een schrijfinrichting (1) om een schrijfhandeling uit te voeren op een schrijfoppervlak (S) van een substraat (P), waarbij de schrijfinrichting een camerasysteem (5) heeft om ten minste een deel van het schrijfoppervlak (S) op te nemen tijdens gebruik, met het kenmerk, dat een gezichtsveld van het camerasysteem ten minste 90 graden bedraagt, bij voorkeur ten minste 110 graden.
2. De pen volgens conclusie 1, waarbij het camerasysteem drie camera-eenheden (5a, 5b, 5c) omvat, met onderling verschillende kijkhoeken, bij voorkeur symmetrisch ten opzichte van een middenlijn van een behuizing van de schrijfinrichting (1) opgesteld, in het bijzonder voor het opnemen van respectieve sets van beelden die het gehele gezichtsveld van het camerasysteem (5) omvatten.
3. De pen volgens een der voorgaande conclusies, waarbij de schrijfinrichting een processor (10) omvat geconfigureerd om van het camerasysteem (5) ontvangen beelden te verwerken om handgeschreven gegevens betreffende handschrift op een opgenomen schrijfoppervlakdeel te bepalen, waarbij de processor (10) bij voorkeur is uitgevoerd voor het evalueren en/of opslaan van gedetecteerde handgeschreven gegevens, waarbij de processor (10) bijvoorbeeld is uitgevoerd om bitmap beelden in vectorruimtegegevens te converteren, bijvoorbeeld onder gebruikmaking van een randdetectiealgoritme, en de resulterende vectorruimtegegevens te verwerken om de handgeschreven gegevens te bepalen.
4. De pen volgens conclusie 3, waarbij de processor (10) is geconfigureerd om een oriëntatie van de schrijfinrichting (1) ten opzichte van het schrijfoppervlak te bepalen, waarbij de processor (10) bij voorkeur is geconfigureerd om een bepaalde oriëntatie van de schrijfinrichting (10) ten

opzichte van het schrijffoppervlak (S) te gebruiken in het transformeren van een coördinatensysteem van bepaalde handgeschreven gegevens naar een coördinatensysteem van het schrijffoppervlak (S).

- 5 5. De pen volgens conclusie 4, omvattende ten minste een traagheidsmeeteenheid (IMU), bijvoorbeeld omvattende een gyroscoop en/of accelerometer, waarbij de processor (10) is uitgevoerd om de oriëntatie van de schrijfinrichting ten opzichte van het schrijffoppervlak te bepalen onder gebruikmaking van sensorresultaten van de ten minste ene traagheidsmeeteenheid.
- 10 6. De pen volgens conclusie 5, omvattende een eerste traagheidsmeeteenheid bij of nabij een proximaal eind van de schrijfinrichting (1) en een tweede traagheidsmeeteenheid bij of nabij een distaal einde van de schrijfinrichting (1).
- 15 7. De pen volgens een der conclusies 3-6, waarbij de processor (10) is uitgevoerd om de van het camerasysteem (5) ontvangen beelden te verwerken om ten minste een rand van het schrijffoppervlak (S) van het substraat te detecteren, waarbij de processor (10) bijvoorbeeld is uitgevoerd om bitmap beelden naar vectorruimtegegevens te converteren, bij voorkeur onder gebruikmaking van een randdetectiealgoritme, en de resulterende
20 vectorruimtegegevens te verwerken om randgegevens betreffende de ten minste ene rand van het schrijffoppervlak (S) van het substraat te bepalen.
- 25 8. De pen volgens conclusie 7, waarbij de processor (10) is uitgevoerd om een oriëntatie en/of positie van de schrijfinrichting ten opzichte van het schrijffoppervlak te bepalen onder gebruikmaking van de bepaalde randgegevens.
9. De pen volgens een der voorgaande conclusies, omvattende een lichtbron (6), bijvoorbeeld een lichtemitterende diode (LED), om ten minste een deel van het schrijffoppervlak (S) te belichten met licht.

10. De pen volgens een der voorgaande conclusies, waarbij de schrijfinrichting (1) een distale kap (3) omvat met ten minste een lichttransmissiedeel (3b), bijvoorbeeld een opening of transparant wanddeel, om invallend licht naar het camerasysteem (5) door te laten.
- 5 11. De pen volgens conclusies 9 en 10, waarbij de kap ten minste een lichtemitterend deel (3f) omvat om belichtingslicht van de lichtbron (6) uit te zenden, waarbij de pen bij voorkeur een lichtgeleidestructuur (9) omvat om licht vanaf de lichtbron naar elk emitterend deel (3f) van de kap (3) te geleiden.
- 10 12. De pen volgens conclusie 9 of 11, omvattende een lichtverstrooier om van de lichtbron afkomstig licht te verstrooien.
13. De pen volgens een der conclusies 9, 11 of 12, waarbij de lichtbron (6) is uitgevoerd om infrarood licht uit te zenden, om ten minste een deel van het schrijfooppervlak (S) met infrarood licht te belichten.
- 15 14. De pen volgens een der conclusies 9, 11, 12 of 13, waarbij de lichtbron (6) is uitgevoerd om zichtbaar licht uit te zenden, om ten minste een deel van het schrijfooppervlak (S) met zichtbaar licht te belichten.
15. De pen volgens een der voorgaande conclusies, waarbij de schrijfinrichting (1) een distale schrijfpunt en een respectief inktreservoir
- 20 heeft om inkt aan de schrijfpunt toe te voeren.

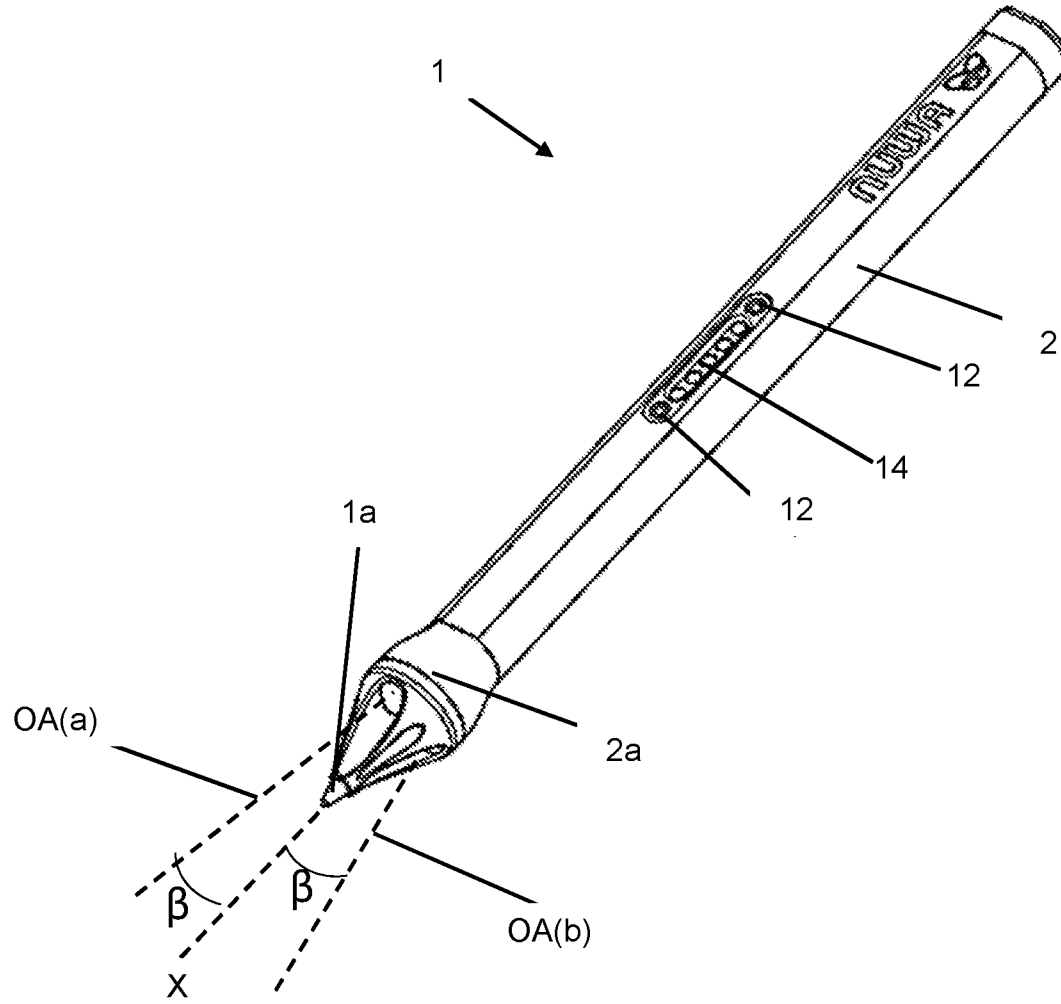
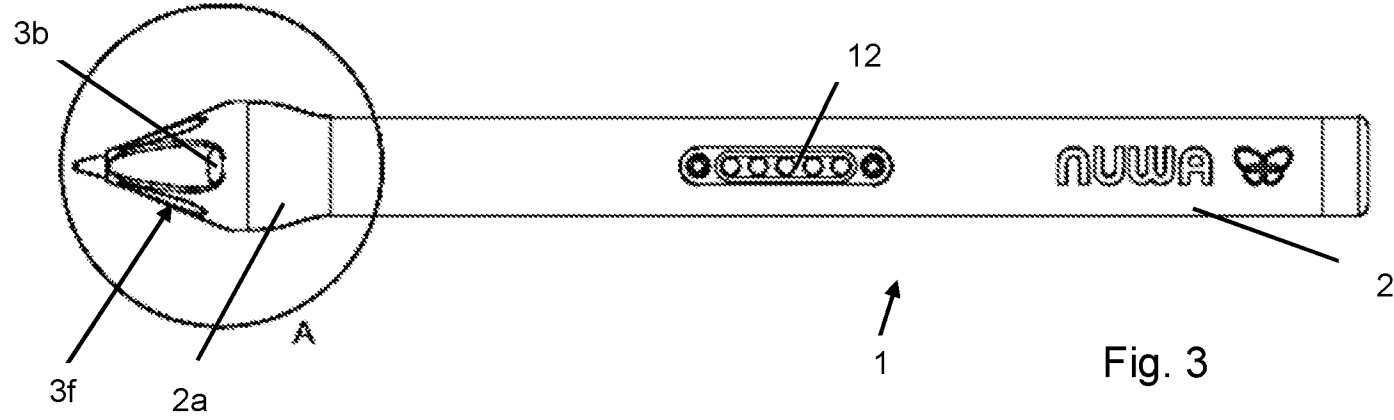
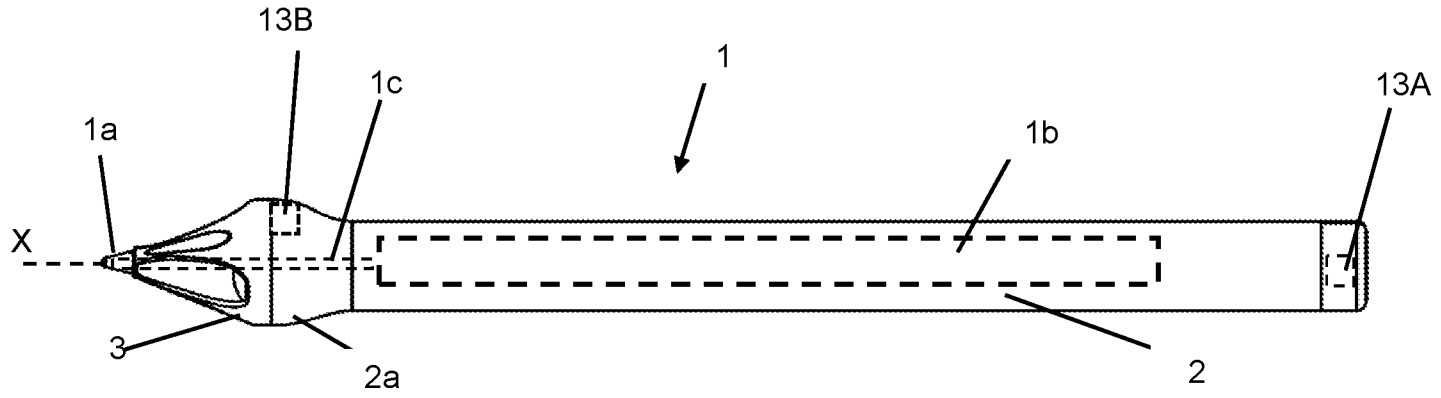

Fig. 1



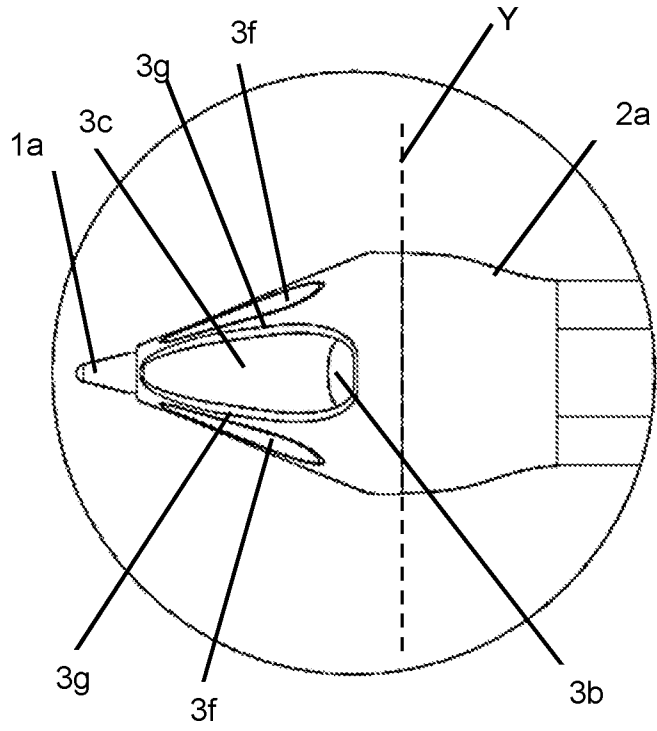

Fig. 4

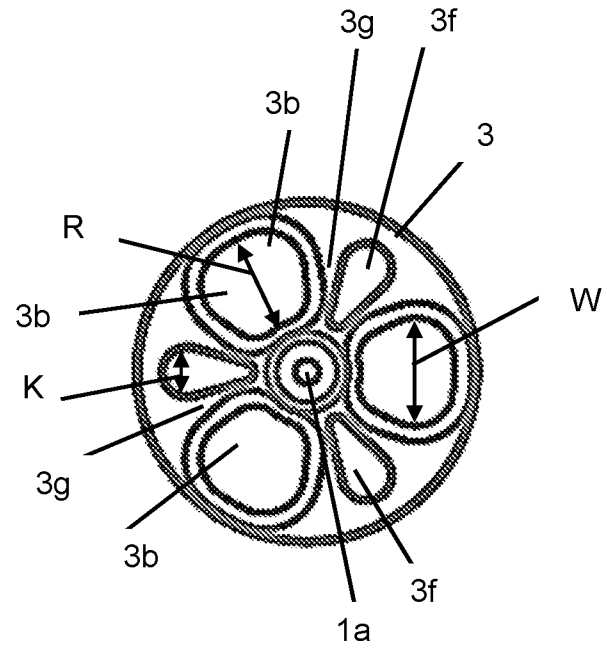

Fig. 5

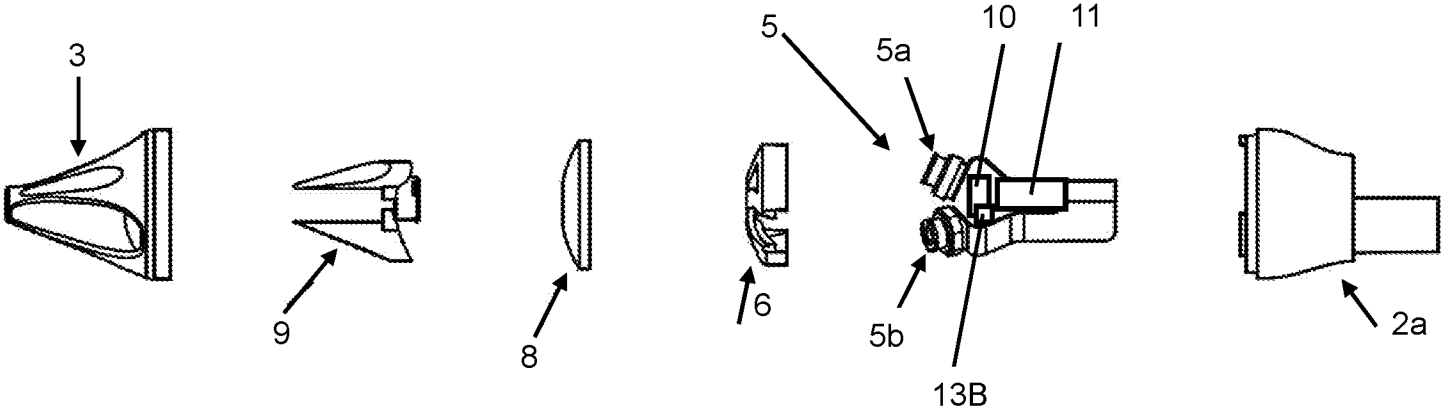
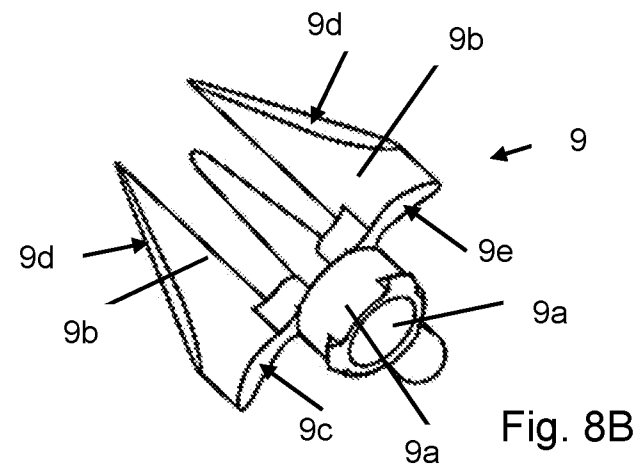
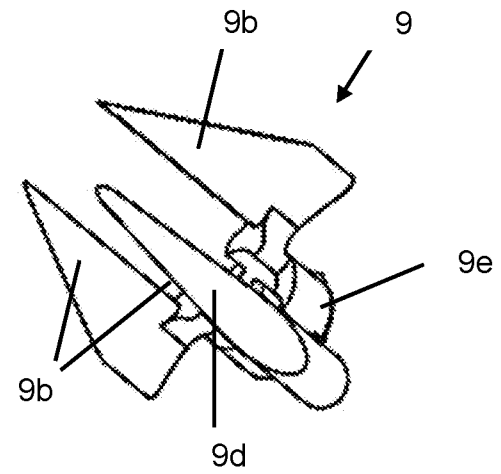
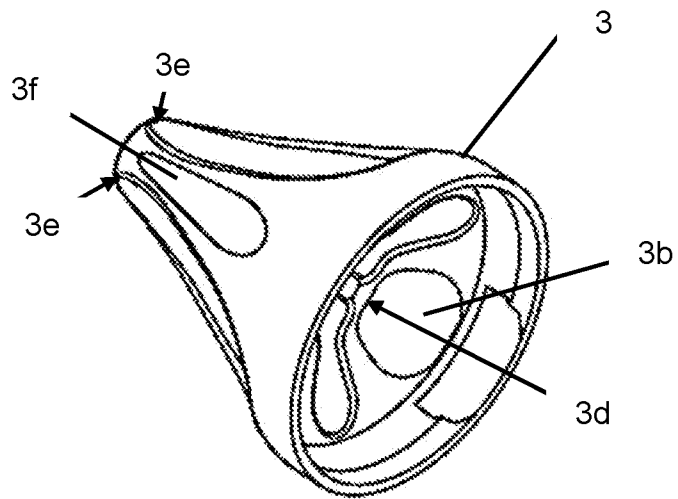
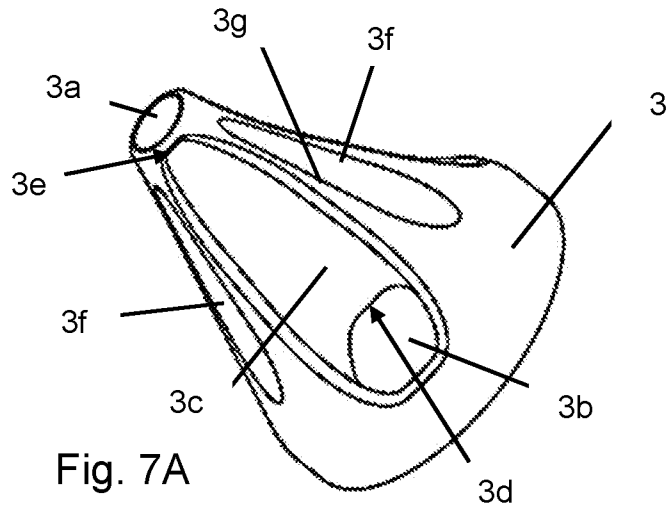

Fig. 6



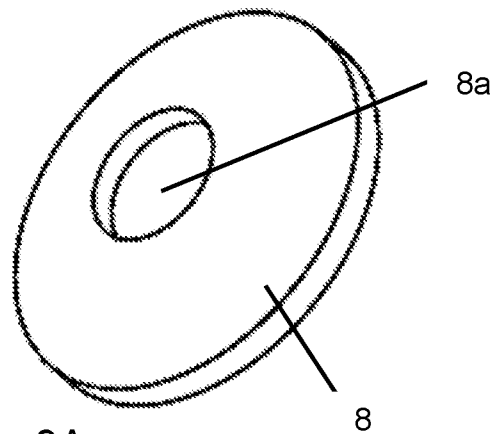

Fig. 9A

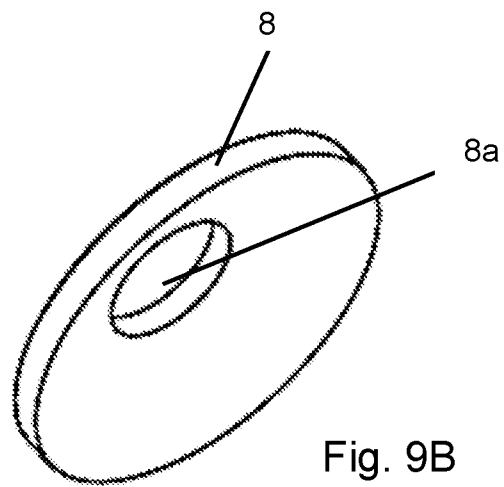

Fig. 9B

6/10

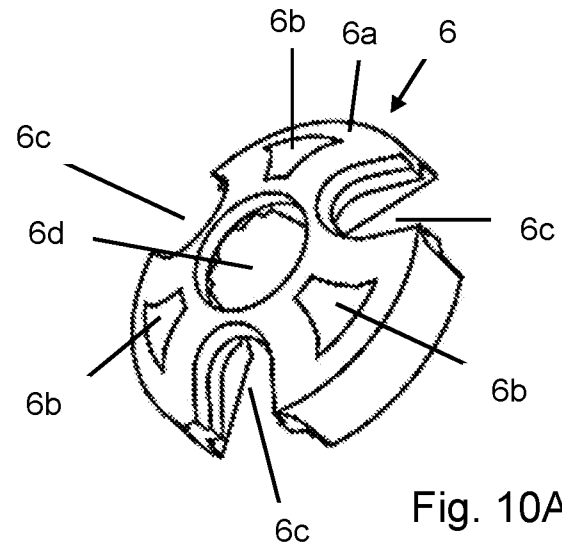

Fig. 10A

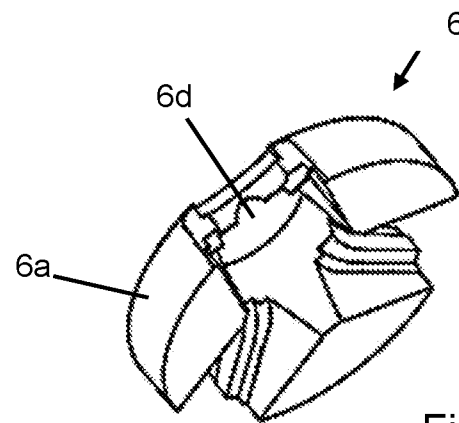

Fig. 10B

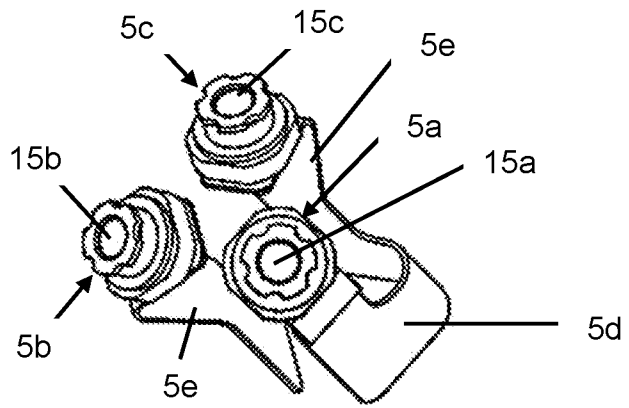

Fig. 11A

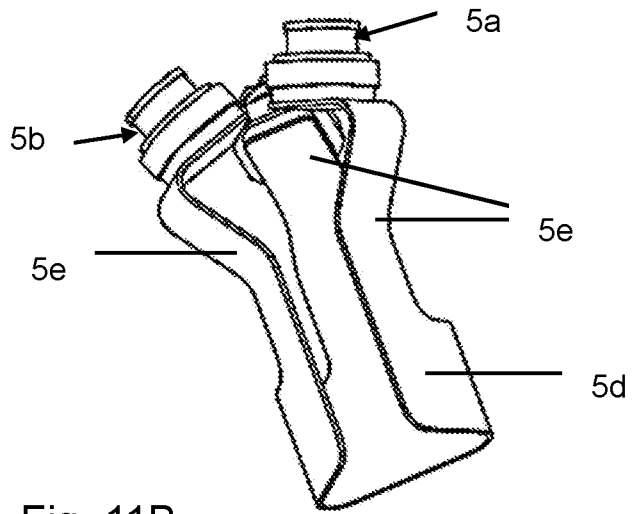

Fig. 11B

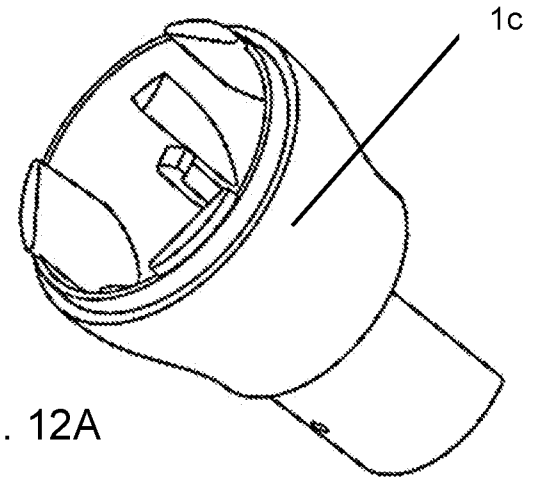

Fig. 12A

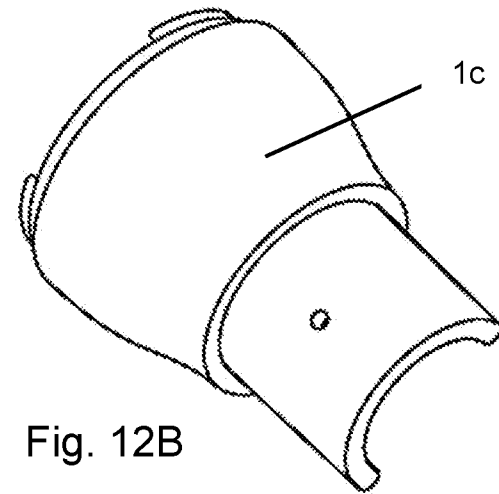

Fig. 12B

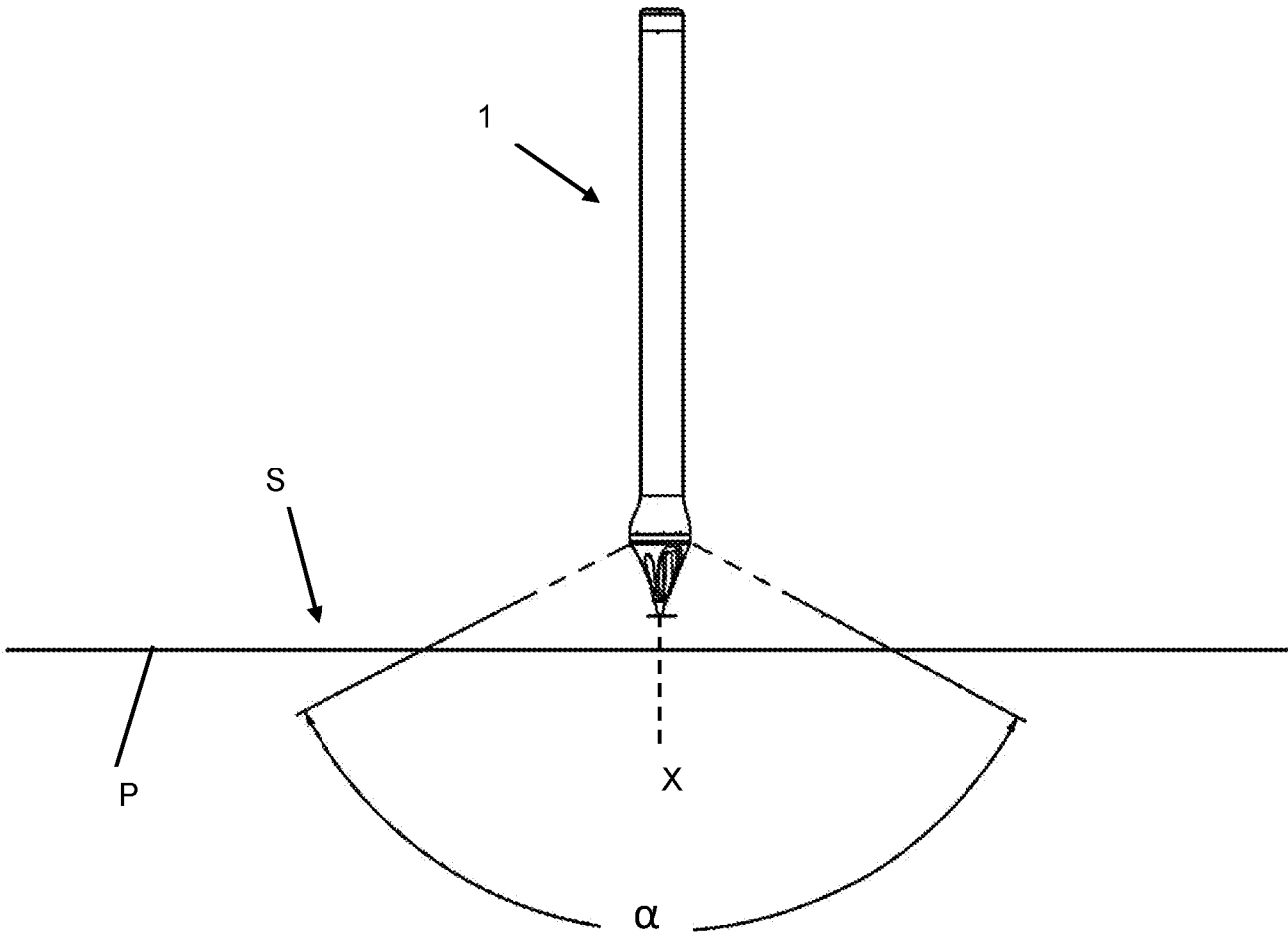

Fig. 13

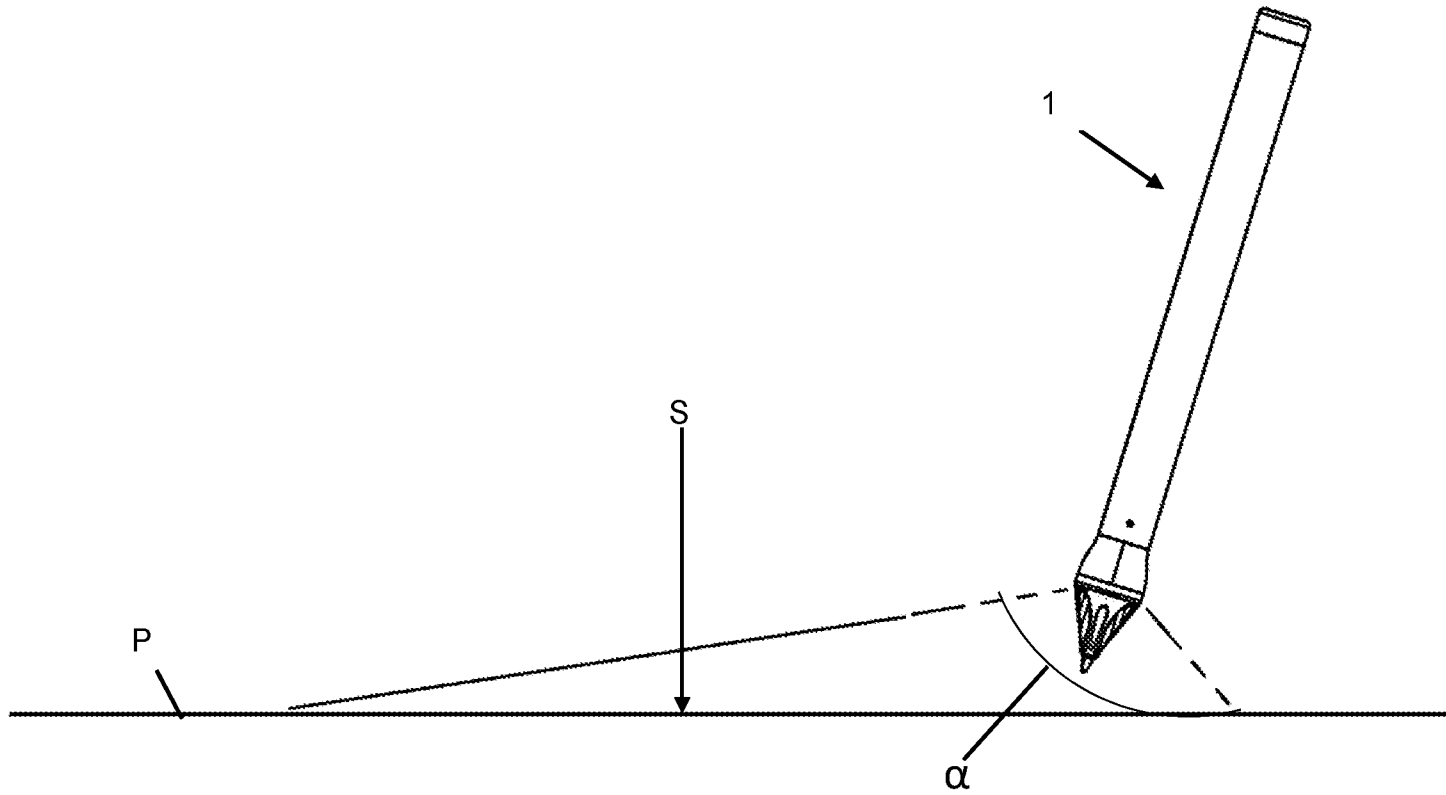

Fig. 14

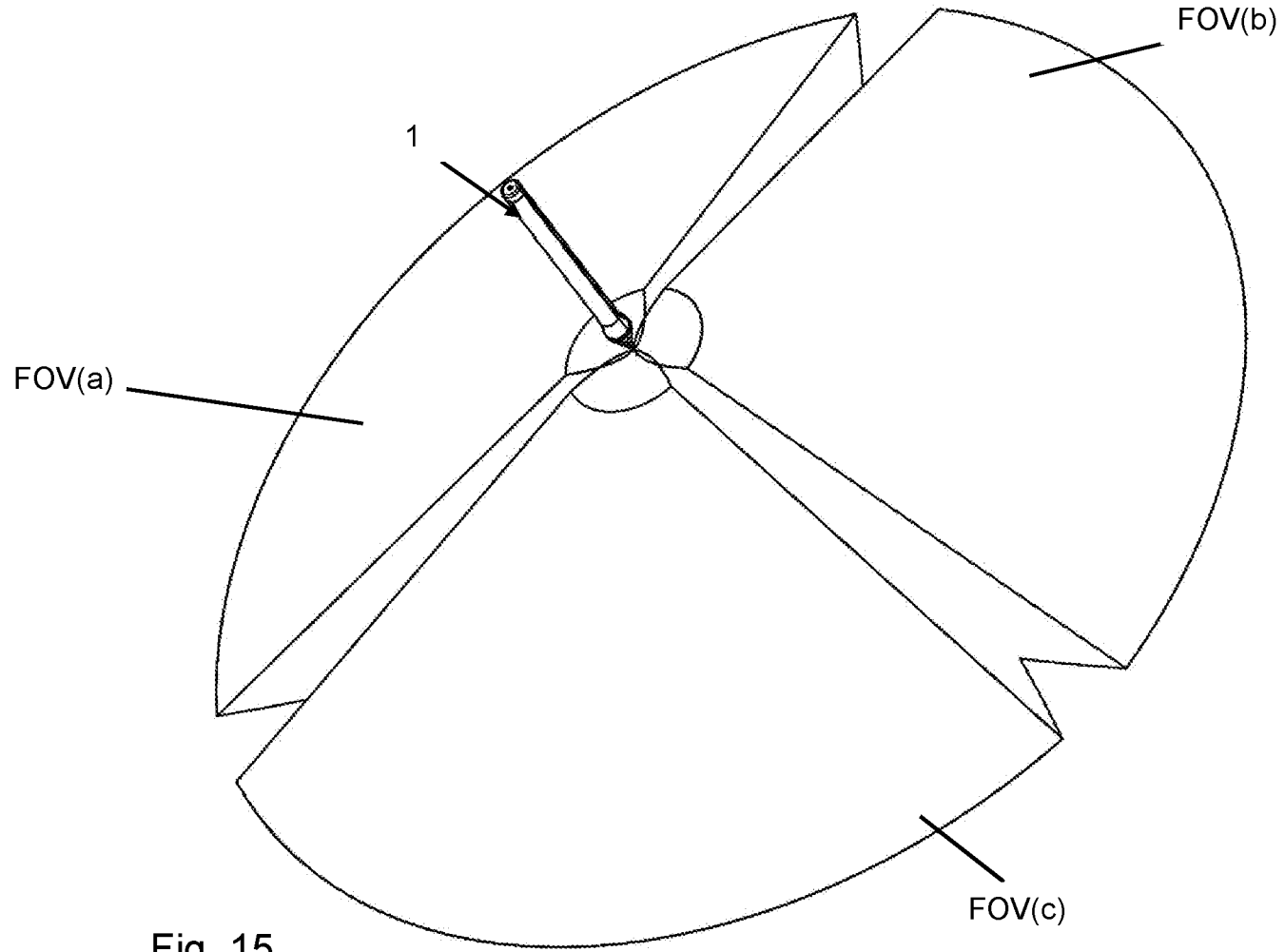

Fig. 15

SAMENWERKINGSVERDRAG (PCT)

RAPPORT BETREFFENDE NIEUWHEIDSONDERZOEK VAN INTERNATIONAAL TYPE

IDENTIFICATIE VAN DE NATIONALE AANVRAGE	KENMERK VAN DE AANVRAGER OF VAN DE GEMACHTIGDE
Nederlands aanvraag nr. 2034260	Indieningsdatum 03-03-2023
	Ingeroepen voorrangsdatum 29-09-2022
Aanvrager (Naam) Nuwa Pen B.V., et al	
Datum van het verzoek voor een onderzoek van internationaal type 25-03-2023	Door de Instantie voor Internationaal Onderzoek aan het verzoek voor een onderzoek van internationaal type toegekend nr. SN83515
I. CLASSIFICATIE VAN HET ONDERWERP (bij toepassing van verschillende classificaties, alle classificatiesymbolen opgeven)	
Volgens de internationale classificatie (IPC) Zie onderzoeksrapport	
II. ONDERZOCHE GEBIEDEN VAN DE TECHNIEK	
Onderzochte minimumdocumentatie	
Classificatiesysteem	Classificatiesymbolen
IPC	Zie onderzoeksrapport
Onderzochte andere documentatie dan de minimum documentatie, voor zover dergelijke documenten in de onderzochte gebieden zijn opgenomen	
III.	GEEN ONDERZOEK MOGELIJK VOOR BEPAALDE CONCLUSIES (opmerkingen op aanvullingsblad)
IV.	GEBREK AAN EENHEID VAN UITVINDING (opmerkingen op aanvullingsblad)

**ONDERZOEKSRAPPORT BETREFFENDE HET
RESULTAAT VAN HET ONDERZOEK NAAR DE STAND
VAN DE TECHNIEK VAN HET INTERNATIONALE TYPE**

Nummer van het verzoek om een onderzoek naar
de stand van de techniek

NL 2034260

A. CLASSIFICATIE VAN HET ONDERWERP
INV. G06F3/0354 G06V30/142
ADD.

Volgens de Internationale Classificatie van octrooien (IPC) of zowel volgens de nationale classificatie als volgens de IPC.

B. ONDERZOCHETE GEBIEDEN VAN DE TECHNIEK

Onderzochte minimum documentatie (classificatie gevolgd door classificatiesymbolen)
G06V G06F

Onderzochte andere documentatie dan de minimum documentatie, voor dergelijke documenten, voor zover dergelijke documenten in de onderzochte gebieden zijn opgenomen

Tijdens het onderzoek geraadpleegde elektronische gegevensbestanden (naam van de gegevensbestanden en, waar uitvoerbaar, gebruikte trefwoorden)

EPO-Internal

C. VAN BELANG GEACHTE DOCUMENTEN

Categorie °	Geciteerde documenten, eventueel met aanduiding van speciaal van belang zijnde passages	Van belang voor conclusie nr.
X, D	US 2016/018910 A1 (WALLOTH CHRISTIAN [DE]) 21 januari 2016 (2016-01-21) in de aanvraag genoemd	1
A	* figuren 1, 3 * * alinea [0003] * * alinea [0025] – alinea [0033] * * alinea [0062] – alinea [0070] * -----	2-15

Verdere documenten worden vermeld in het vervolg van vak C.

Leden van dezelfde octroofamilie zijn vermeld in een bijlage

° Speciale categorieën van aangehaalde documenten

"A" niet tot de categorie X of Y behorende literatuur die de stand van de techniek beschrijft

"D" in de octrooiaanvraag vermeld

"E" eerdere octrooi(aanvraag), gepubliceerd op of na de indieningsdatum, waarin dezelfde uitvinding wordt beschreven

"L" om andere redenen vermelde literatuur

"O" niet-schriftelijke stand van de techniek

"P" tussen de voorrangdatum en de indieningsdatum gepubliceerde literatuur

"T" na de indieningsdatum of de voorrangdatum gepubliceerde literatuur die niet bezwarend is voor de octrooiaanvraag, maar wordt vermeld ter verheldering van de theorie of het principe dat ten grondslag ligt aan de uitvinding

"X" de conclusie wordt als niet nieuw of niet inventief beschouwd ten opzichte van deze literatuur

"Y" de conclusie wordt als niet inventief beschouwd ten opzichte van de combinatie van deze literatuur met andere geciteerde literatuur van dezelfde categorie, waarbij de combinatie voor de vakman voor de hand liggend wordt geacht

"&" lid van dezelfde octroofamilie of overeenkomstige octrooipublicatie

Datum waarop het onderzoek naar de stand van de techniek van internationaal type werd voltooid

31 augustus 2023

Verzenddatum van het rapport van het onderzoek naar de stand van de techniek van internationaal type

Naam en adres van de instantie

European Patent Office, P.B. 5818 Patentlaan 2
NL - 2280 HV Rijswijk
Tel. (+31-70) 340-2040,
Fax: (+31-70) 340-3016

De bevoegde ambtenaar

Nash, Michael

**ONDERZOEKSRAPPORT BETREFFENDE HET
RESULTAAT VAN HET ONDERZOEK NAAR DE STAND
VAN DE TECHNIEK VAN HET INTERNATIONALE TYPE**

Informatie over leden van dezelfde octrooifamilie

Nummer van het verzoek om een onderzoek naar
de stand van de techniek

NL 2034260

In het rapport genoemd octrooigeschrift	Datum van publicatie	Overeenkomend(e) geschrift(en)	Datum van publicatie
US 2016018910	A1	21-01-2016	
		CN 104981817 A	14-10-2015
		DE 102013200080 A1	10-07-2014
		EP 2941737 A1	11-11-2015
		JP 2016509291 A	24-03-2016
		US 2016018910 A1	21-01-2016
		WO 2014106655 A1	10-07-2014

WRITTEN OPINION

File No. SN83515	Filing date (<i>day/month/year</i>) 03.03.2023	Priority date (<i>day/month/year</i>) 29.09.2022	Application No. NL2034260
International Patent Classification (IPC) INV. G06F3/0354 G06V30/142			
Applicant Nuwa Pen B.V., et al			

This opinion contains indications relating to the following items:

- Box No. I Basis of the opinion
- Box No. II Priority
- Box No. III Non-establishment of opinion with regard to novelty, inventive step and industrial applicability
- Box No. IV Lack of unity of invention
- Box No. V Reasoned statement with regard to novelty, inventive step or industrial applicability; citations and explanations supporting such statement
- Box No. VI Certain documents cited
- Box No. VII Certain defects in the application
- Box No. VIII Certain observations on the application

	Examiner Nash, Michael
--	---------------------------

WRITTEN OPINION

Box No. I Basis of this opinion

1. This opinion has been established on the basis of the latest set of claims filed before the start of the search.
2. With regard to any **nucleotide and/or amino acid sequence** disclosed in the application, this opinion has been established on the basis of a sequence listing:
 - a. forming part of the application as filed.
 - b. furnished subsequent to the filing date for the purposes of search,
 - accompanied by a statement to the effect that the sequence listing does not go beyond the disclosure in the application as filed.
3. With regard to any nucleotide and/or amino acid sequence disclosed in the application, this opinion has been established to the extent that a meaningful opinion could be formed without a WIPO Standard ST.26 compliant sequence listing.
4. Additional comments:

Box No. V Reasoned statement with regard to novelty, inventive step or industrial applicability; citations and explanations supporting such statement

1. Statement

Novelty	Yes: Claims	2-15
	No: Claims	1
Inventive step	Yes: Claims	2-15
	No: Claims	1
Industrial applicability	Yes: Claims	1-15
	No: Claims	

2. Citations and explanations

see separate sheet

Box No. VII Certain defects in the application

see separate sheet

Box No. VIII Certain observations on the application

see separate sheet

Re Item V

Reasoned statement with regard to novelty, inventive step or industrial applicability; citations and explanations supporting such statement

1 Reference is made to the following document that has already been cited by the Applicant:

D1 US 2016/018910 A1 (WALLOTH CHRISTIAN [DE]) 21 januari 2016 (2016-01-21)

2 The present application does not meet the criteria of patentability, because the subject-matter of Claim 1 is not novel.

This can be seen with respect to document D1 (see in particular paragraphs [0066] to [0070], [0025] to [0033] as well as figures 3 and 1) that discloses according to **all** the features of Claim 1:

Handschriftdetectiepen (1), omvattende een schrijfinrichting om een schrijfhandeling uit te voeren op een schrijfoppervlak (13) van een substraat (4, 5), waarbij de schrijfinrichting een camerasysteem (2; 21, 22) heeft om ten minste een deel van het schrijfoppervlak (13) op te nemen tijdens gebruik (16, 16', 16''), met het kenmerk, dat een gezichtsveld van het camerasysteem ten minste 90 graden bedraagt, bij voorkeur ten minste 110 graden (paragraphs [0028], [0069]).

3 Dependent Claim 2 describes the camera system comprising three camera units, with mutually different viewing angles, preferably arranged symmetrically with respect to a centre line of a writing device housing, in particular for recording respective sets of images covering the entire field of view of the camera system.

3.1 Document D1, however, that is regarded as being the closest prior art, discloses a camera system comprising two camera units and thus a combination of Claims 1 and 2 would be novel over the disclosure of document D1

3.2 The problem to be solved by a combination of Claims 1 and 2 may be regarded as providing a pen or stylus that may be held in any orientation i.e. it may be rotated by any angle while being held in the hand of a user.

3.3 The solution to this problem proposed by the combination of Claims 1 and 2 of the present application is considered as involving an inventive step for the following reasons:

Pattern identification can be reliably performed no matter the orientation of the pen or stylus. i.e. no matter how the pen or stylus is held by the user, image recognition is performed reliably.

- 3.4 The Applicant is thus suggested to file a new set of claims whereby present Claim 1 is replaced by a new Claim 1 consisting of the combination of present Claims 1 and 2.

Re Item VII.

Certain defects in the international application

- 1 The independent claims should have been cast in the two-part form, with those features known in combination from the prior art (see document D1) being placed in a preamble and with the remaining features being included in a characterising part.

Re Item VIII.

Certain observations on the international application

- 1 Claim 1 is not clear because the claim fails to explain how the field of view of at least 90 degrees, preferably at least 110 degrees is achieved. It would appear that this is solved by the restriction of Claim 2 in that the field of view of three cameras that are symmetrically arranged at the tip of the stylus are combined, without this Claim 1 is missing essential features.